



CATALOGUE OF CERAMIC IGNITERS

NET New Eco Technologies
Grzegorz Pilarczyk
Sienkiewicza Str. 56
48-385 Otmuchów
Poland

e-mail: biuro@net-poland.eu
www.net-poland.eu



tel. +48 603 375 692
tel. +48 668 641 122



SAFE CERAMIC PELLET IGNITERS

GSP 230/315-B



NET New Eco Technologies
Grzegorz Pilarczyk
Sienkiewicza Str. 56
48-385 Otmuchów
Poland

e-mail: biuro@net-poland.eu
www.net-poland.eu



tel. +48 603 375 692
tel. +48 668 641 122

NET
NEW ECO TECHNOLOGIES

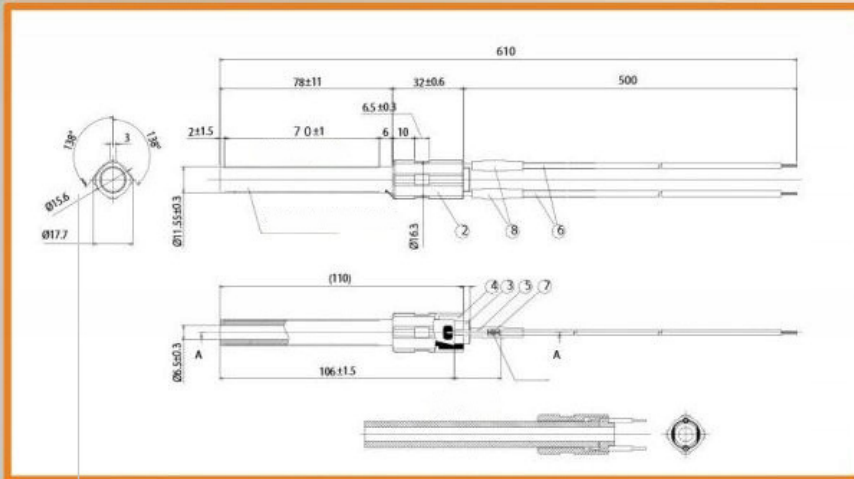
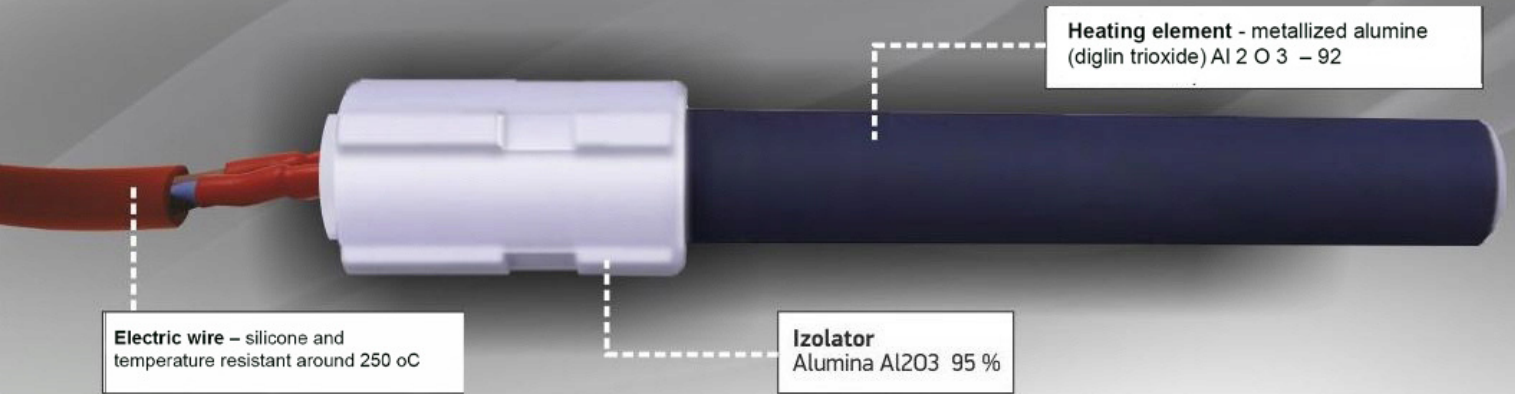

Description/Used materials

1. Heating element - metallized alumine (diglin trioxide)
Al₂O₃ – 92 %,
2. Electric wire – silicone and temperature resistant around 250 oC
3. Insulation - thermo-retractable silicone – dielectric endurance – min 6 kV
4. Terminal connective electrodes and power wire
5. Insulation - thermo-retractable silicone – dielectric endurance – min 6 kV

Feature	
Current supply	AC 240V ± 10 % AC 230V ± 6 % AC 220V ± 4 %
Power consumption	345 W (AC240 V) 315 W (AC230 V) 295 W (AC220 V)
Electrical resistance	33,5 ~ 49,13 Ω
1. Warm-up time 2. Starting current 3. Minimum power 4. Minimum temperature	To 1000 oC - les than 60s temp. max 1100 oC - after 120s More than 7 A More than 300 W 870 oC
Insulation resistance	More than 50 MΩ
Dielectric strength	Current flow less than 5 mA
Strength of sealing compound for tear	More than 29,4 N (more than 3 kg)



NET New Eco Technologies
Grzegorz Pilarczyk
Sienkiewicza Str. 56
48-385 Otmuchów
Poland

e-mail: biuro@net-poland.eu
www.net-poland.eu



tel. +48 603 375 692
tel. +48 668 641 122

NET
NEW ECO TECHNOLOGIES

SAFE CERAMIC PELLET IGNITERS

GSP-4 230/315-B



NET New Eco Technologies
Grzegorz Pilarczyk
Sienkiewicza Str. 56
48-385 Otmuchów
Poland

e-mail: biuro@net-poland.eu
www.net-poland.eu



tel. +48 603 375 692
tel. +48 668 641 122

NET
NEW ECO TECHNOLOGIES

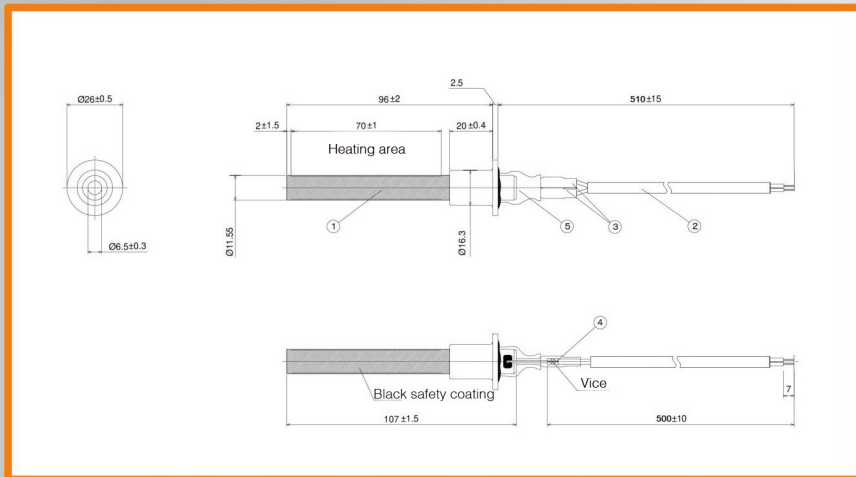
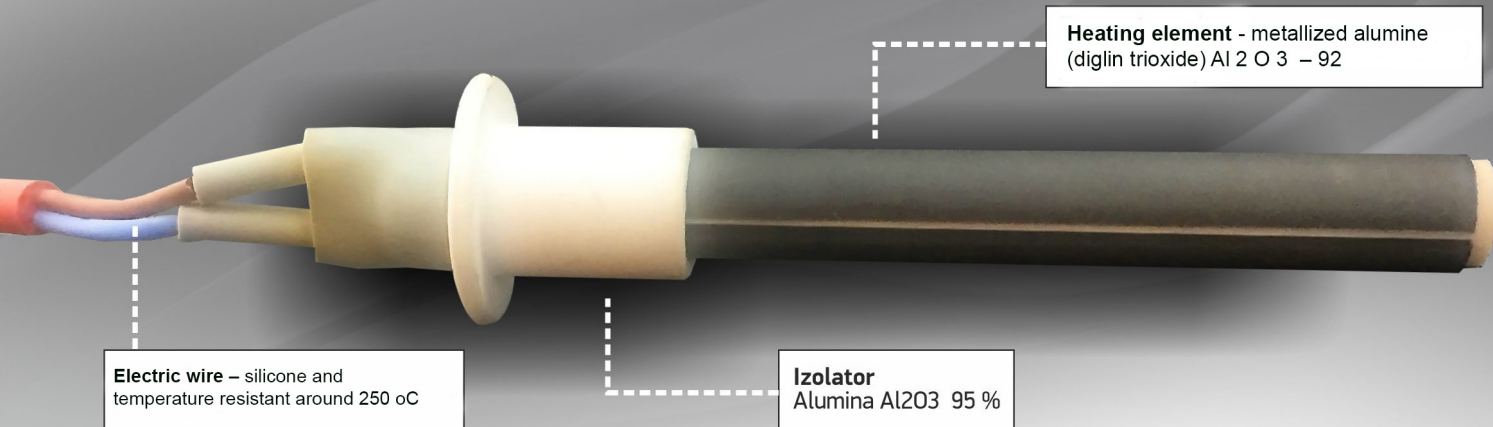

Description/Used materials

1. Heating element - metallized alumine (diglin trioxide) $Al_2O_3 - 92\%$
2. Electric wire - silicone and temperature resistant around 250 oC
3. Insulation - thermo-retractable silicone - dielectric endurance - min 6 kV
4. Terminal connective electrodes and power wire
5. Insulation - thermo-retractable silicone - dielectric endurance - min 6 kV

Feature	
Current supply	AC 240V ± 10 % AC 230V ± 6 % AC 220V ± 4 %
Power consumption	345 W (AC240 V) 315 W (AC230 V) 295 W (AC220 V)
Electrical resistance	33,5 ~ 49,13 Ω
1. Warm-up time	To 1000 oC - les than 60s
2. Starting current	temp. max 1100 oC - after 120s
3. Minimum power	More than 7 A
4. Minimum temperature	More than 300 W 870 oC
Insulation resistance	More than 50 MΩ
Dielectric strength	Current flow less than 5 mA
Strength of sealing compound for tear	More than 29,4 N (more than 3 kg)



NET New Eco Technologies
Grzegorz Pilarczyk
Sienkiewicza Str. 56
48-385 Otmuchów
Poland

e-mail: biuro@net-poland.eu
www.net-poland.eu



tel. +48 603 375 692
tel. +48 668 641 122

NET
NEW ECO TECHNOLOGIES

SAFE CERAMIC PELLET IGNITERS

GSP-3 230/315-B



NET New Eco Technologies
Grzegorz Pilarczyk
Sienkiewicza Str. 56
48-385 Otmuchów
Poland

e-mail: biuro@net-poland.eu
www.net-poland.eu



tel. +48 603 375 692
tel. +48 668 641 122

NET
NEW ECO TECHNOLOGIES

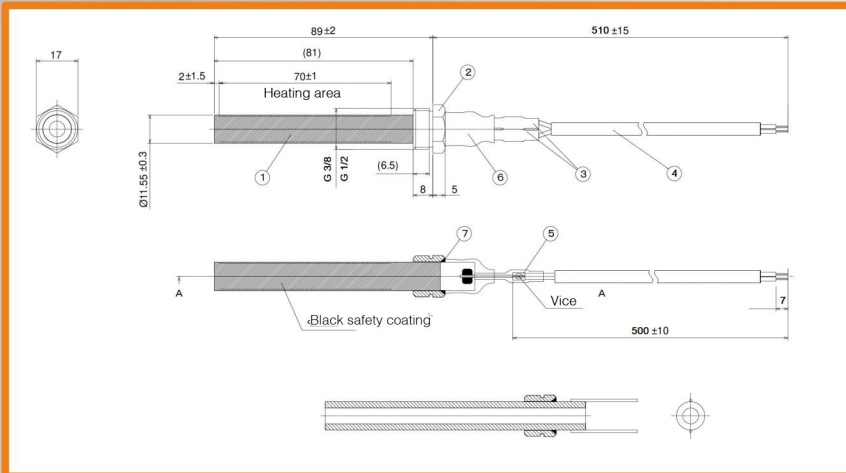
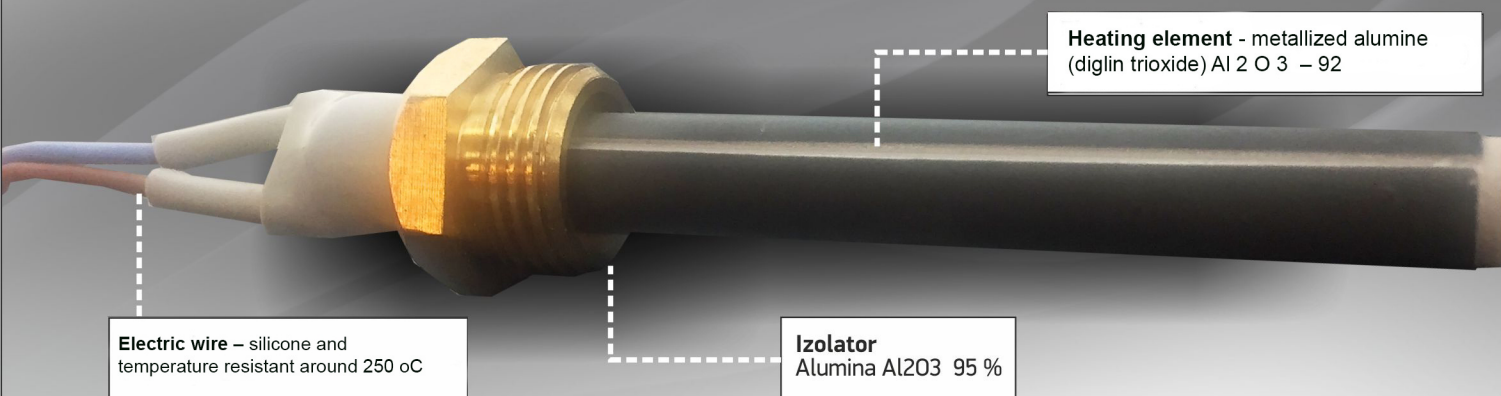

Description/Used materials

1. Heating element - metallized alumine (diglin trioxide) $Al_2O_3 - 92 \%$,
2. Mounting screw – bronz (inside screw $\frac{1}{2}$ or $\frac{3}{8}$ inch)
3. Insulation - thermo-retractable silicone – dielectric endurance – min 6 kV
4. Electric wire – silicone and temperature resistant around 250 °C
5. Terminal connective electrodes and power wire
6. Insulation - thermo-retractable silicone
7. Ceramic sealing – harden ceramic mass



Feature	
Current supply	AC 240V $\pm 10 \%$ AC 230V $\pm 6 \%$ AC 220V $\pm 4 \%$
Power consumption	345 W (AC240 V) 315 W (AC230 V) 295 W (AC220 V)
Electrical resistance	33,5 ~ 49,13 Ω
1. Warm-up time	To 1000 °C - les than 60s
2. Starting current	temp. max 1100 °C - after 120s
3. Minimum power	More than 7 A
4. Minimum temperature	More than 300 W 870 °C
Insulation resistance	More than 50 M Ω
Dielectric strength	Current flow less than 5 mA
Strength of sealing compound for tear	More than 29,4 N (more than 3 kg)

NET New Eco Technologies
Grzegorz Pilarczyk
Sienkiewicza Str. 56
48-385 Otmuchów
Poland

e-mail: biuro@net-poland.eu
www.net-poland.eu



tel. +48 603 375 692
tel. +48 668 641 122

NET
NEW ECO TECHNOLOGIES

SAFE CERAMIC PELLET IGNITERS

GSP 230/170



NET New Eco Technologies
Grzegorz Pilarczyk
Sienkiewicza Str. 56
48-385 Otmuchów
Poland

e-mail: biuro@net-poland.eu
www.net-poland.eu



tel. +48 603 375 692
tel. +48 668 641 122

NET
NEW ECO TECHNOLOGIES

Igniter for fuel's ignition installation in pellet burners

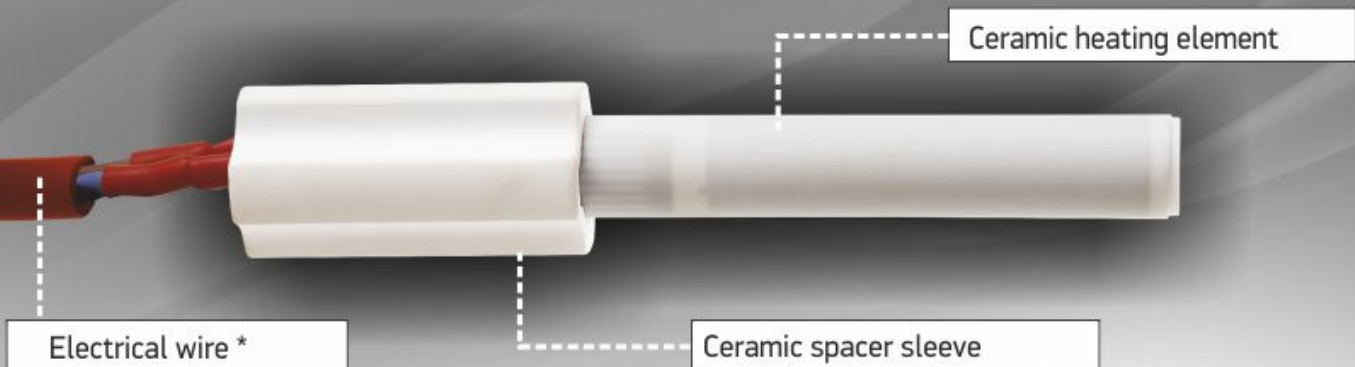

*Standard length – 40 cm. Possible change of igniter's wire length on customer's request.



- Designed for ignition installation in pellet burners
- Construction which enables flow of the air inside and outside the heating element
- Average igniter's life – 100 000 ignition cycles (depending on operating conditions e.g. quality of pellet)
- Premium quality ceramics enables operation in high temperatures
- Construction is resistant to corrosion and oxidation unlike traditional tubular igniters
- Total elimination of dangerous short circuits– electrical insulators are not required
- Igniter is resistant to burnout in the event of air fan's breakdown
- Electrical wire used in the igniter is resistant to high temperature – 170°C

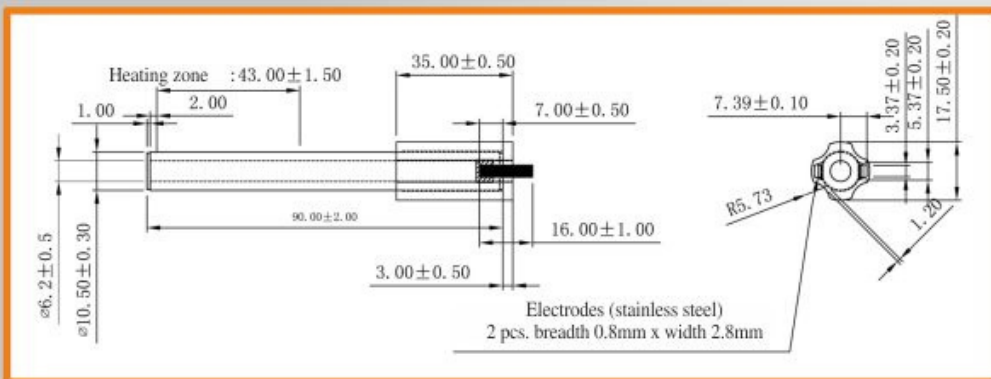

Technical parameters

Power/Voltage

GSP 115 ≈ 200W /115V
GSP 230 ≈ 200W /230V

Max. temp. of permanent operation
1000°C (momentary: 1200°C)

Pellet's ignition time
60-90 seconds (depending on position of a heater in furnace)

NET New Eco Technologies
Grzegorz Pilarczyk
Sienkiewicza Str. 56
48-385 Otmuchów
Poland

e-mail: biuro@net-poland.eu
www.net-poland.eu



tel. +48 603 375 692
tel. +48 668 641 122

NET
NEW ECO TECHNOLOGIES